

Last version of this manual
IP2378EN - 2022-09-27

Ditec



Ditec CROSS18-20

Technical Manual

Automation for sliding gates

(translation of the original instructions)

Index

General safety precautions	3
Declaration of incorporation of partly completed machinery	5
UK Declaration of Conformity	6
1. Technical data	7
1.1 Operating instructions	10
1.2 Machinery Directive	10
2. Installation type	11
3. Dimensions	12
4. Main components	12
5. Installation	12
5.1 Preliminary checks	12
5.2 Base plate preparation	13
5.3 Gear motor installation	13
5.4 Rack installation	14
5.5 Installing and adjusting lever limit switches	14
5.6 Installing and adjusting magnetic limit switches	14
6. Electrical connections	15
7. Apply manual release label	18
8. Routine maintenance plan	18

Legend



This symbol indicates instructions or notes relating to safety which require special attention.



This symbol indicates useful information for the correct operation of the product.

General safety precautions



ATTENTION! Important safety instructions.

Follow these instructions carefully. Failing to follow the instructions contained in this manual may result in serious personal injury or damage to the equipment.

Keep these instructions for future reference.

This manual and the manuals for any accessories can be downloaded at www.ditecautomations.com

This installation manual is intended for qualified personnel only • Installation, electrical connections and adjustments must be carried out by qualified personnel in accordance with Good Engineering Practice and in compliance with the regulations in force • Read the instructions carefully before starting to install the product. Incorrect installation could cause dangerous situations • Check the integrity of the product before starting installation.



Packaging materials (plastic, polystyrene, etc.) should not be discarded into the environment or left within the reach of children, as they are potentially dangerous • Do not install the product in an explosive environment or atmosphere. The presence of flammable gases or fumes is a serious safety hazard • Ensure that the operating temperature range indicated in the technical data is compatible with the place of use • Before installing the motorisation, check that the existing structure and the support and guide components have the required strength and stability. Check the stability and smoothness of the guided part and ensure that there is no risk of derailment or falling. Make all structural modifications necessary to create safety barriers and protect or segregate all crushing, shearing, conveyance and danger zones in general. The manufacturer of the motorisation system is not liable for non-compliance with Good Engineering Practice in building the door or gate to be motorised or for any deformation that may occur during use • The safety devices (photocells, sensitive edges, emergency stops, etc.) should be installed in consideration of the standards and directives in force, Good Engineering Practice, the installation environment, the operating logic of the system and the forces created by the motorised door or gate • For handling

equipment weighing more than 20 kg, provide suitable lifting aids (handles, eyebolts, etc.) • The safety devices must protect any crushing, shearing, conveyance and danger zones of the motorised door or gate. Apply the markings provided for by the regulations in force to identify danger zones • Each installation must have visible indication of the identification data for the motorised door or gate • Before connecting the power supply, make sure that the data on the plate correspond to the electricity distribution network data. Provide an omnipolar switch/disconnector on the power network with a contact opening distance of 3 mm or more. Check that, upstream of the electrical system, there is a suitable residual-current device and surge protector, in compliance with Good Engineering Practice and the regulations in force. • When required, connect the motorised door or gates to an effective earthing system as indicated by the safety regulations in force • Before handing over the system to the end user, make sure that the automation is adequately adjusted to meet the operational and safety requirements and that all the command, safety and manual release devices are working correctly.



During maintenance and repair work, disconnect the power supply before opening the cover to access the electrical parts

- Only qualified personnel should remove the protective cover for the automation system
- Please refer to the control unit's technical manual for further safety instructions.



Electronic parts should be handled using grounded anti-static conductive bracelets. The manufacturer of the motorisation is not liable for safety or correct operation if incompatible components are installed • Use only original spare parts for any product repairs or replacements • The installer must provide all information relating to the automatic, manual and emergency operation of the motorised door or gate, and provide the user of the system with the instructions for use and safety.

Declaration of incorporation of partly completed machinery (Directive 2006/42/EC, Annex II-B)

We,
ASSA ABLOY Entrance Systems AB
Lodjursgatan 10
SE-261 44 Landskrona
Sweden,

declare, under our sole responsibility, that the type of equipment with the name:
Ditec CROSS18EP Sliding gate automations with electromechanical limit switches
Ditec CROSS18VEP Sliding gate automations with magnetic limit switches
Ditec CROSS20VEI Sliding gate automations with inverter and magnetic limit switches

complies with the following directives and their amendments:

2006/42/EC Machinery Directive (MD), regarding the following essential health and safety requirements: 1.1.2, 1.1.3, 1.2.1, 1.2.2, 1.2.3, 1.2.4.2, 1.2.6, 1.3.9, 1.4.3, 1.7.2, 1.7.3, 1.7.4, 1.7.4.1, 1.7.4.2.

2014/30/EU Electromagnetic Compatibility Directive (EMCD)

2014/53/EU Radio Equipment Directive (RED)

2011/65/EU Restriction of Hazardous Substances (RoHS 2)

2015/863/EU Restriction of Hazardous Substances (RoHS Amendment 2)

Harmonised European standards which have been applied:

EN 61000-6-3:2007 + A1:2011 + AC:2012

EN 61000-6-2:2019

EN 60335-1:2012 + AC:2014 + A11:2014 + A13:2017

+ A1:2019 + A14:2019 + A2:2019

EN 60335-2-103:2015

EN 60529:1991 + A1:2000 + A2:2013 + AC:2016

EN 62233:2008 + AC:2008

EN ISO 13849-1:2015

Other standards or technical specifications which have been applied:

IEC 60335-1:2010 + C1:2010 + C2:2011 + A2:2013 + C1:2014 + A2:2016 + C1:2016

IEC 60335-2-103:2006 + A1:2010

EN 12453:2017.

The manufacturing process guarantees that the equipment complies with the technical documentation.

Do not put equipment into service until the installed finished Automatic Entrance System has been declared compliant with Directive 2006/42/EC on Machinery.

Responsible for the technical documentation:

Matteo Fino
BSP Ind channel & Gate Automation
Ditec S.p.A.
Largo U. Boccioni, 1
21040 Origgio (VA)
Italy

Signed on behalf of ASSA ABLOY Entrance Systems AB by:

Place	Date	Signature	Position
Origgio	2022-09-27	Matteo Fino	Head of Ind channel & Gate Automation

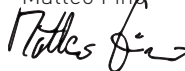

UK Declaration of Conformity

We:

ASSA ABLOY Entrance Systems AB
Lodjursgatan 10
SE-261 44 Landskrona
Sweden

Declare under our sole responsibility that the types of equipment with names:

Ditec CROSS18EP Sliding gate automations with electromechanical limit switches
Ditec CROSS18VEP Sliding gate automations with magnetic limit switches
Ditec CROSS20VEI Sliding gate automations with inverter and magnetic limit switches

Comply with the following directives and their amendments:

- Supply of Machinery (Safety) Regulations 2016
- Electromagnetic Compatibility Regulations 2016
- Radio Equipment Regulations 2017
- The Restriction of the Use of Certain Hazardous Substances in Electrical and Electronic Equipment Regulations 2012 (RoHS)

Harmonized European standards that have been applied:

EN 61000-6-3:2007 + A1:2011 + AC:2012
EN 61000-6-2:2019
EN 60335-1:2012 + AC:2014 + A11:2014 + A13:2017 + A1:2019 + A14:2019 + A2:2019
EN 60529:1991 + A1:2000 + A2:2013 + AC:2016
EN 62233:2008 + AC:2008
EN ISO 13849-1:2015

Other standards or technical specifications that have been applied:

IEC 60335-1:2010 + C1:2010 + C2:2011 + A2:2013 + C1:2014 + A2:2016 + C1:2016
EN 12453:2017

The manufacturing process ensures the compliance of the equipment with the technical file.

Responsible for technical file:

Matteo Fino
BSP Ind channel & Gate Automation
Ditec S.p.A.
Largo U. Boccioni, 1
21040 Origgio (VA)
Italy

Signed for and on behalf of ASSA ABLOY Entrance Systems AB by:

Place	Date	Signature	Position
Origgio	2022-09-27	Matteo Fino	Head of Ind channel & Gate Automation



1. Technical data

	Ditec CROSS18EP	Ditec CROSS18VEP	Ditec CROSS20VEI
Power supply	230 V~ 50 Hz		230 V~ 50/60 Hz
Power input	3 A		3.5 A
Motor type	230 V~		230 V 3~
Thrust	1800 N		2000 N
Gate speed	0.2 m/s		0,1 - 0,3 m/s
Max stroke *	36 m		60 m
Gate maximum weight	1800 kg		2000 kg
Service class	HEAVY (tested up to 350,000 cycles)		VERY HEAVY (tested up to 450,000 cycles)
Intermittent operation	S2= 60 min (T= 25°C) S3= 55% (T= 25°C)		S2= 90 min (T= 25°C) S3= 90% (T= 25°C)
Cycles / hour **	19 (T= 25°C)		27 (T= 25°C)
Continuous cycles **	33 (T= 25°C)		44 (T= 25°C)
Temperature	 -20°C +55°C -35°C +55°C with NIO active		
Protection rating	IPX4		
Electronic panel	LCA85		LCU43A
Radio frequency	433,92 MHz (code ZENRS) - 868,35 MHz (code ZENPRS)		
	ZENRS receiver module included, ZENPRS optional.		
Noise level L_{PA}	≤70 dB (A)		
Limit switch	lever	magnetic	magnetic

* The maximum stroke of the gate has been calculated considering a default speed of 20 cm/s.

** Cycles are estimated considering a gate with a length of 10 m and factory settings [default speed of 20 cm/s (see Chart 1.1 and Chart 1.2). CROSS20VEI however allows a maximum speed of 30 cm/s (configurable). Each cycle is considered an opening maneuver followed by a closing maneuver.

Chart.1.1

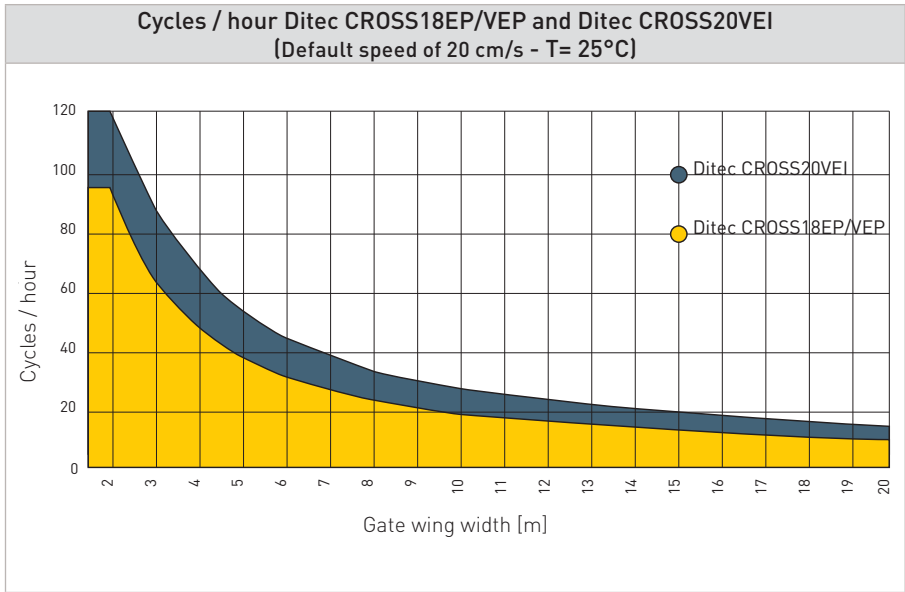
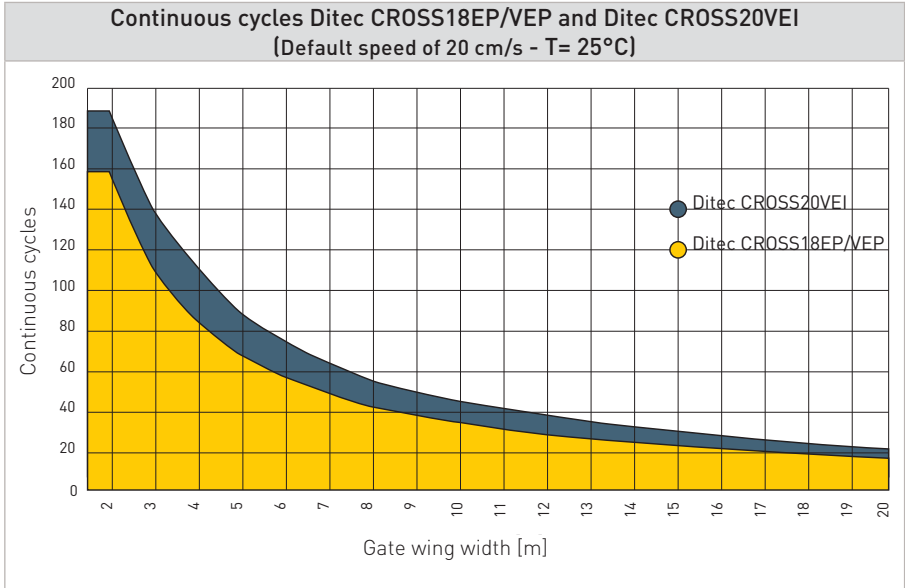

Chart.1.2



The product lifespan is conditioned by the extent of other onerous conditions: with reference to Tab. 1.1, various corrective factors have been assessed in relation to the weight and width of the wing and the usage conditions; when taken as a whole, they affect the lifespan of the operating unit (see Chart 1.3).

Tab. 1.1

Index of conditioning factors			
		Ditec CROSS18EP/VEP	Ditec CROSS20VEI
Gate wing weight	1000 Kg	-	-
	>1200 Kg	10	-
	>1400 Kg	20	10
	>1600 Kg	30	20
	>1800 Kg	-	30
Gate wing width	> 10 m	10	
	> 20 m	20	
Wheels diameter <100 mm		10	
Saline environment		10	
Installed safety edge		10	
VA/VC speed setting higher than the default values		10	
OB/CB speed setting lower than the default values		10	
R1/R2/DT/RF/r1/r2 force setting higher than the default values		10	

Chart 1.3

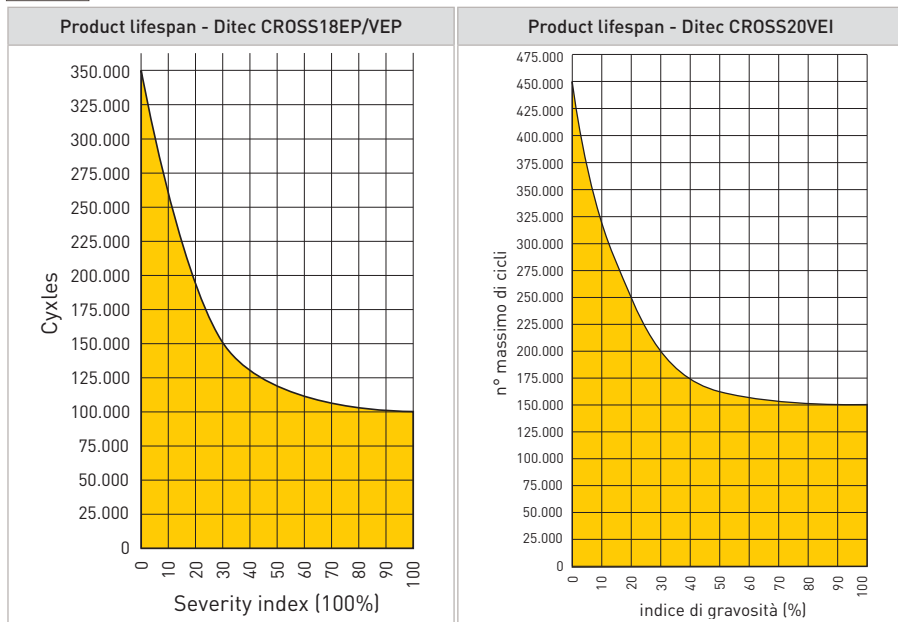

1.1 Operating instructions

USE: for condominium, industrial and commercial, car park entrances with heavy driveway or pedestrian use.

- Not suitable for gates or doors incorporating pedestrian auxiliary doors.
- Usage performance refers to the recommended weight (approx. 2/3 of the maximum permitted weight) e ad una temperatura ambiente di 25°C. Use with the maximum permitted weight may diminish the above performance.
- The class of service, usage times and number of consecutive cycles are suggestions. They are statistically measured under average usage conditions and cannot be certain for every single case.
- For each automatic entrance, there are variables such as friction, balancing and environmental conditions that can substantially change the operating life and quality of the automatic entrance or some of its components (including the automated mechanisms). It is up to the installer to implement safety factors appropriate for each particular installation.

1.2 Machinery Directive

According to the Machinery Directive (2006/42/EC), the installer who motorises a door or gate has the same obligations as the manufacturer of a machine, and as such must:

- prepare the technical documentation, which must contain the documents indicated in Annex V of the Machinery Directive;
(the technical documentation must be kept and made available to the competent national authority for at least ten years, starting from the date of construction of the motorised door);
- draw up the EC statement of conformity according to Annex II-A of the Machinery Directive and hand it over to the customer;
- affix the CE marking to the motorised door in accordance with point 1.7.3 of Annex I of the Machinery Directive.

2. Installation type

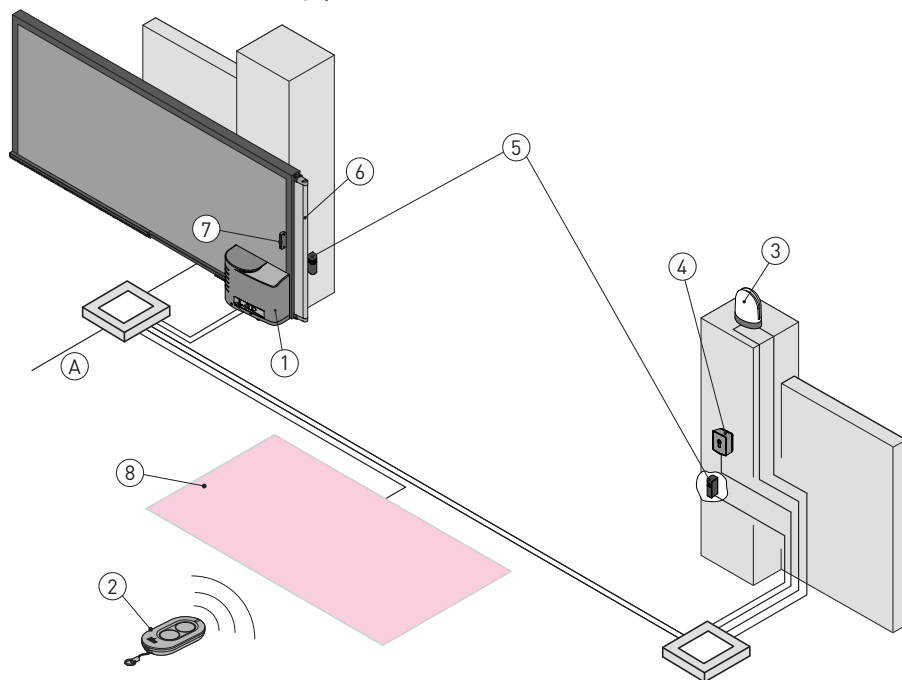

Ref.	Code	Description	Cable
1	Ditec CROSS18EP	230 V gear motor with lever limit switch/built-in electronic control panel	3G x 1,5 mm ²
	Ditec CROSS18VEP	230 V gear motor with magnetic limit switch/built-in electronic control panel	
	Ditec CROSS20VEI	230 V gear motor with magnetic limit switch/built-in electronic control panel	
2	ZEN	Transmitter	/
3	FLM	Flashing light 230 V	2 x 1 mm ²
	FL24	Flashing light 24 V	
		Antenna (integrated in the flashing light)	RG-58 coax cable (50 Ω)
4	AXK5	Key selector switch	4 x 0,5 mm ²
	AXR7	Transponder	
	AXK4	Digital combination wireless keypad	/
A		Connect the power supply to a certified-compliant omnipolar switch (not included) with a contact opening distance of at least 3mm. Connection to the mains must be via an independent conduit, separated from the connections to the command and safety devices.	
5	LIN2	Photocells	4 x 0,5 mm ²
	LIN2B	Photocells	
	AXP2	Photocells	
	LAB4	Photocells IP55	
6	SOFAP20	Safety edge	2 x 0,5 mm ² min
	SOF2M20-SOF3M20	Safety edge	
	SOFA15-SOFA20-SOFA25	Safety edge	
7	GOPAV	Radio system for sensitive edges	/
8	LAB9	Magnetic loop detector	2 x 1,5 mm ²

 Connect the power supply to an omnipolar approved switch with an opening distance of the contacts of at least 3 mm (not included). The connection to the mains must be done on an independent channel separate from the connections to the command and safety devices.

3. Dimensions

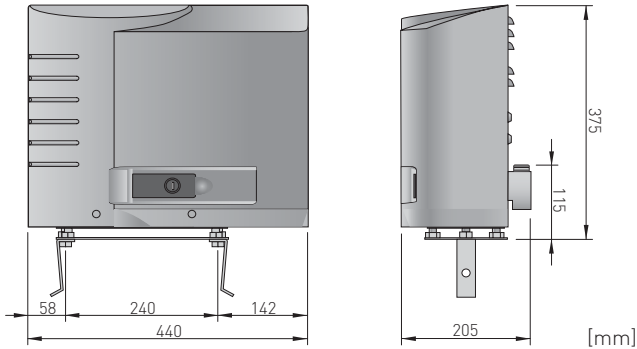

4. Main components

CROSS18EP

CROSS18VEP/CROSS20VEI

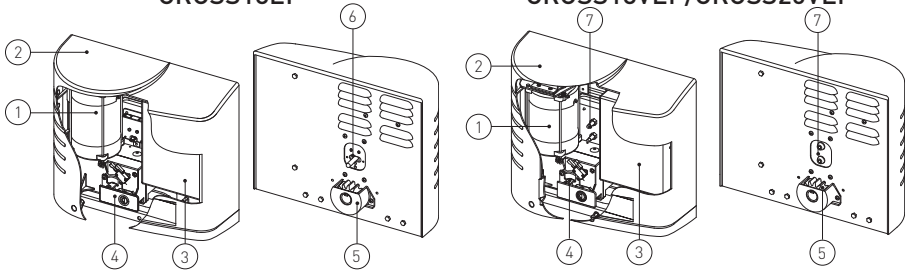

Ref.	Description
1	Motor
2	Cover
3	Control panel
4	Manual release
5	Pinions
6	Lever limit switch unit
7	magnetic limit switch unit

5. Installation

Guaranteed operation and stated performance can only be achieved with DITEC accessories and safety devices.

All measurements shown are in mm, unless otherwise indicated.

5.1 Preliminary checks

Check the stability of the wing (derailment and side falls) and the condition of the running wheels and that the upper guides do not create friction.

The runner should be firmly anchored to the ground, fully exposed along its entire length and should not have any irregularities that could hinder the movement of the wing.

Opening and closing stops must be installed.

If the gate has gaps, these should be covered to eliminate shearing points.

Safety devices should be installed at the ends of the wing to reduce impact forces.

i NOTE: Check that the gate cannot fall out of the guides.

5.2 Base plate preparation

- Insert the anchor bolts on the base plate and secure them with the nuts supplied.
- Prepare a concrete pad with the anchor bolts and base plate embedded in it, which must be level and clean, in accordance with the measurements shown in the figure.



NOTE: If the concrete pad is already in place, the base plate can be fixed using M12 plugs (not supplied by us) to allow for height adjustment

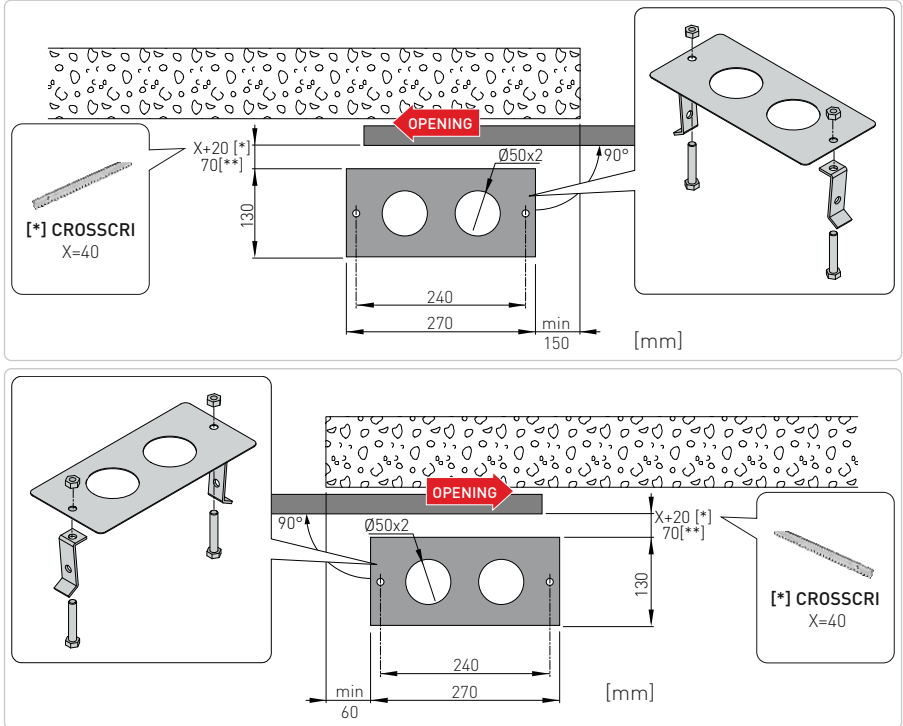

5.3 Gear motor installation

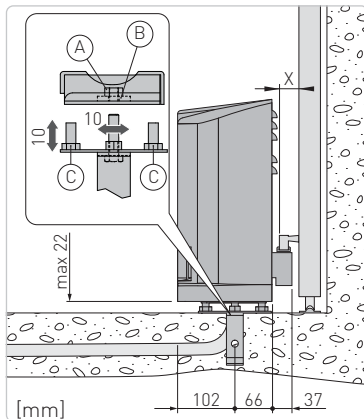

- Unlock the gear motor (see INSTRUCTIONS FOR USE) and remove the key. Unscrew the two front screws and remove the cover [2].
- Install the gear motor on the base plate.
- Gear motor adjustments.
Horizontally by sliding the gear motor over the slots in the anchoring brackets (max. 10 mm).
Vertical with the four levelling screws [C].



NOTE: When making vertical adjustments, keep the gear motor slightly raised in relation to the base plate to allow the rack to be secured and any subsequent adjustments to be made.



ATTENTION: the gear motor must be suitably raised off the ground to avoid flooding.

5.4 Rack installation

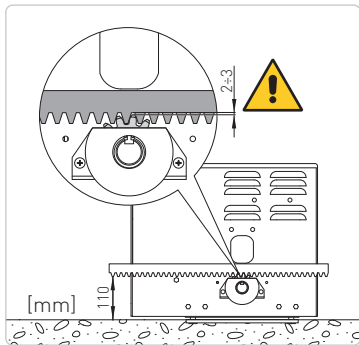

- Unlock the gear motor (see INSTRUCTIONS FOR USE) and move the gate to the open position.
- Place the rack on the pinion and, by sliding the gate manually, secure it along its entire length.
- After fastening, adjust the gear motor vertically so that there is a gap of approximately 2-3 mm between the pinion and rack
- Securely lock the gear motor.
- Lightly lubricate the rack and pinion after assembly. Manually check that the gate slides smoothly and without friction.
- Firmly secure the gearmotor by means of nuts [A] - (see 5.3).

5.5 Installing and adjusting lever limit switches

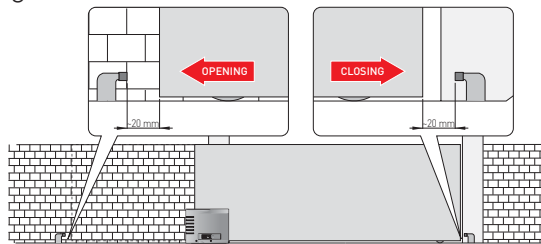
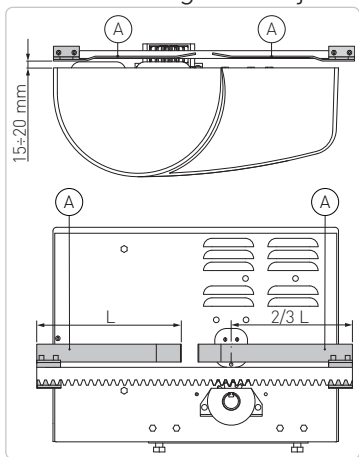

- Manually move the door to the fully open position and fix the limit switch brackets [A] on the rack so that the lever limit switch exceeds the length of the bracket by approximately 2/3. Repeat the operation with the wing fully closed.
- Adjust the position of the limit switch bracket [A] after making a few manoeuvres so that the gate stops approximately 20 mm before the opening and closing stops.

5.6 Installing and adjusting magnetic limit switches

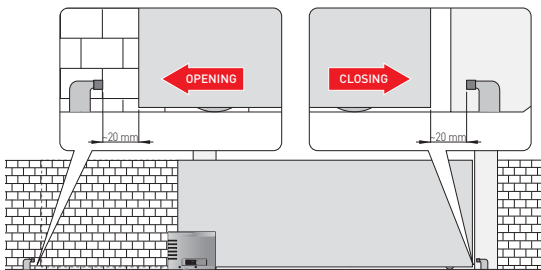
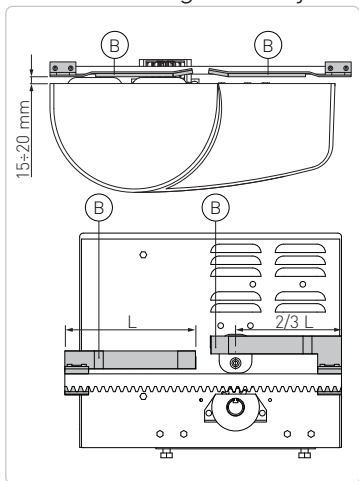

- Manually move the door to the fully open position and fix the limit switch brackets [B] on the rack so that the position of the sensor exceeds the length of the bracket by approximately 2/3. Repeat the operation with the wing fully closed.
- Adjust the position of the limit switch bracket [B] after a making few manoeuvres so that the gate stops approximately 20 mm before the opening and closing stops.

6. Electrical connections

	CROSS18EP	CROSS18VEP	CROSS20VEI
Electronic panel	LCA85	LCA85	LCU43A

! Before connecting the power supply, make sure that the data on the plate correspond to the electricity distribution network data. Provide an omnipolar switch/disconnector on the power network with a contact opening distance of 3 mm or more. Check that there is a suitable residual-current device and surge protector upstream of the electrical system. Use an H05RN-F 3G1.5 electrical cable and connect it to terminals L (brown) and N (blue) inside the automation system. Connect the earth cable (yellow/green) to the earth terminal.

! **ATTENTION:** always observe L-N polarity when connecting to the mains.

Secure the cable by means of the cable clamp and only unsheath it at the terminal. Connections to the electrical distribution network and any other low-voltage conductors (230 V), in the section outside the automation system, must be made with corrugated pipes that are independent and separate from the path of connections to the control and safety devices (SELV = Safety Extra Low Voltage). Make sure there are no sharp edges that could damage the power cord.

! Ensure that the mains connection cables, any other low-voltage cables (230 V), and safety extra-low voltage safety accessory connection cables in the portion located inside the product are kept well separated from the gear motor body.

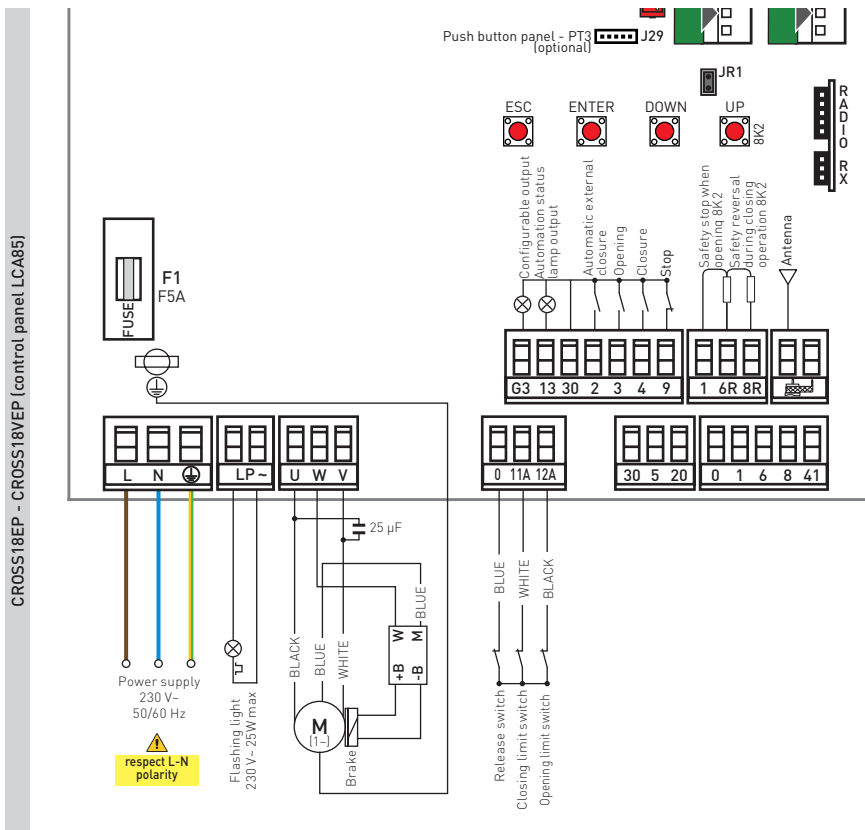

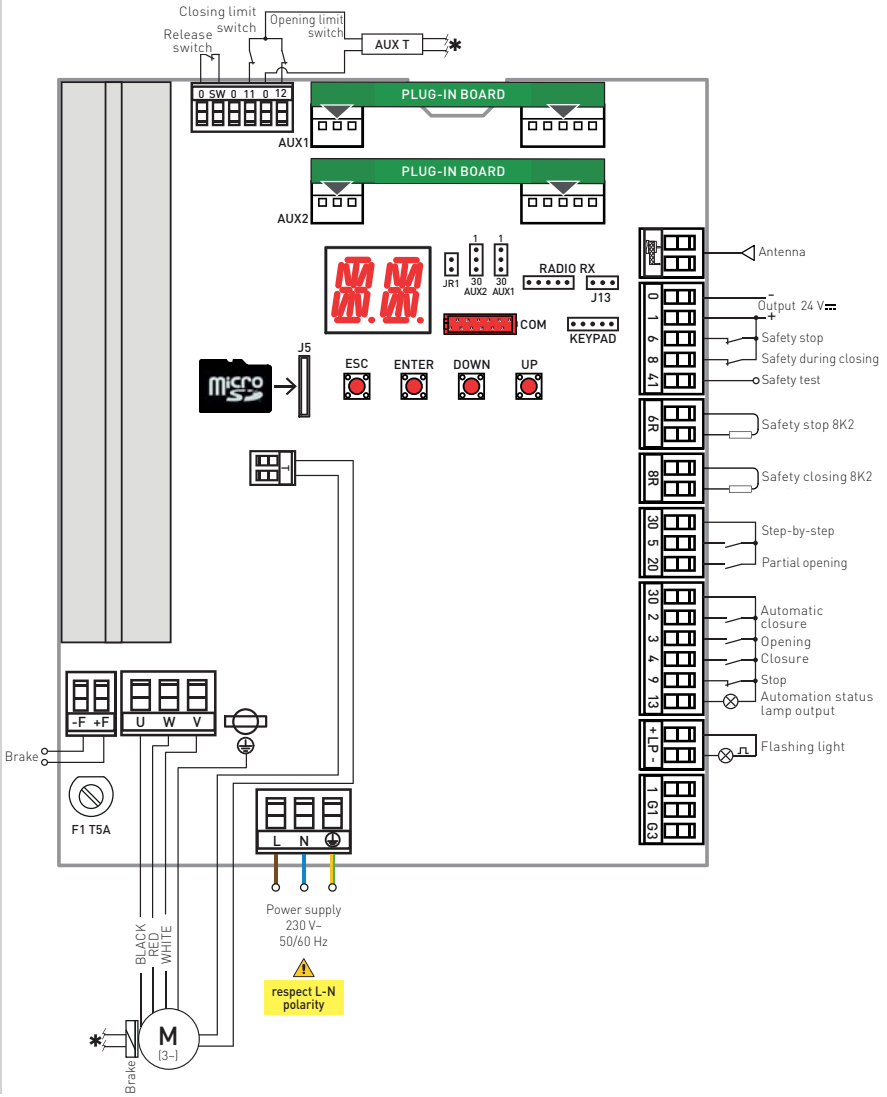

7. Apply manual release label

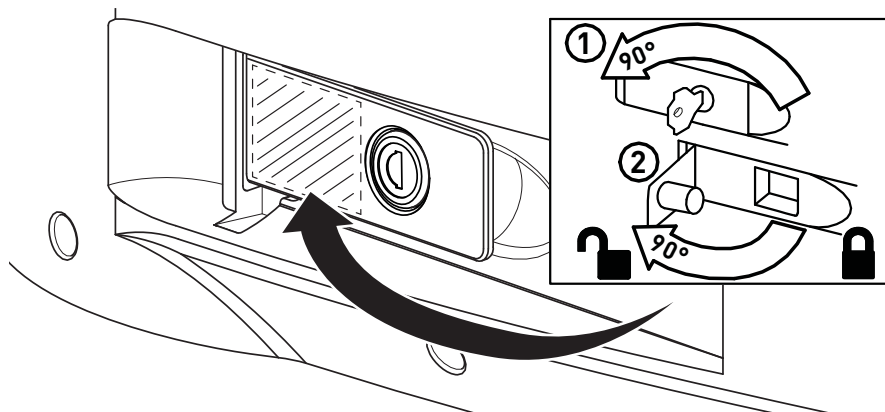

8. Routine maintenance plan

Carry out the following operations and checks every 6 months, depending on the how much the automation system is used.

Switch off the 230 V~ power supply and unlock the gear motor:

- Visually check that the gate, the fixing brackets and the existing structure have the necessary mechanical strength and are in good condition.
- Check the gate-motor alignment and the distance (2-3 mm) between the pinion groove and the rack crest.
- Clean the wheel guides, rack and pinion of the gear motor and lightly lubricate the rack and pinion of the gear motor. Manually check that the gate slides smoothly and without friction. Switch on the 230 V~ power supply and lock the gear motor:
 - Check that the limit switches work correctly.
 - Check force settings.
 - Check the correct operation of all control and safety functions.



NOTE: For spare parts, please see the spare parts list.

All the rights concerning this material are the exclusive property of ASSA ABLOY Entrance Systems AB. Although the contents of this publication have been drawn up with the greatest care, ASSA ABLOY Entrance Systems AB cannot be held responsible in any way for any damage caused by mistakes or omissions in this publication. We reserve the right to make changes without prior notice.

Copying, scanning or changing in any way is expressly forbidden unless authorised in writing by ASSA ABLOY Entrance Systems AB.

 The crossed-out wheelie bin symbol indicates that the product should be disposed of separately from normal household waste. The product should be recycled in accordance with local environmental regulations for waste disposal. By separating a product marked with this symbol from household waste, you will help reduce the volume of waste sent to incinerators or land-fill and minimise any potential negative impact on human health and the environment.



ASSA ABLOY Entrance Systems AB
Lodjursgatan 10
SE-261 44, Landskrona
Sweden
© ASSA ABLOY